

707 STEREO POWER
AMPLIFIER

INSTRUCTION BOOK

Q U A D

CONTENTS

	page
IMPORTANT NOTES	2
INTRODUCTION	4
PACKING LIST AND UNPACKING THE EQUIPMENT	5
GUARANTEE AND PRODUCT REGISTRATION	5
SERVICE ARRANGEMENTS	5
ACCESSORIES SUPPLIED	6
INSTALLATION	6
Checking the AC Power Supply	7
Connecting to the AC Power Supply	8
Connection to the Preamplifier	8
FRONT VIEW	9
REAR VIEW	9
USE OF CORRECT CONNECTORS AND CABLES	10
CONNECTING LOUDSPEAKERS	10
Loudspeaker Connection	10
Neutrik Plug Connection	11
Neutrik Speaker Plug Assembly	11
SIGNAL CONNECTION	12
QUADLINK CABLE	12
BI AND TRI-AMPLIFICATION	12
SWITCHING ON AND OFF	13
AMPLIFIER PROTECTION	13
LOUDSPEAKER PROTECTION	13
QUAD ELECTROSTATIC LOUDSPEAKERS	13
LOUDSPEAKER PHASING	13
HEADPHONES	13
MAINTENANCE	13
SPECIFICATION	14
Power Output Graph	15

IMPORTANT NOTES

European Union Directives

Quad equipment is designed to comply with the legal provisions of EU Directives 89/336/EC and 72/23/EEC. The standards which have been applied were those in force at the time of the introduction of the product. The product bears the CE mark.



Compliance cannot guarantee perfect performance. In the very rare circumstance that you experience problems you should first try to locate and remedy the origin of any disturbance. A further option is to relocate the Quad equipment in order to reduce the interference. Your dealer should be able to provide assistance if the problem persists.

FCC Rule 15 Class B

This equipment has been tested and found to comply with the limits for a Class B device, pursuant to Part 15 of the FCC Rules. These limits are designed to provide reasonable protection against harmful interference in a residential installation. If this equipment does cause harmful interference to radio or television reception, which can be determined by turning the equipment off and on, the user is encouraged to try to correct the interference by one or more of the following measures:

- Reorient or relocate the receiving antenna
- Increase the separation between the equipment and the receiver
- Connect the equipment into an outlet on a circuit different to that to which the receiver is attached
- Consult the dealer or an experienced radio/TV technician for help

This Class B apparatus meets all the requirements of the Canadian Interference Causing Equipment Regulations.

Information to the user:

Alteration or modifications carried out without appropriate authorisation may invalidate the user's right to operate the equipment.

It is always good practice to switch off equipment before connecting or disconnecting signal leads. This will prevent unpleasant and loud noises coming from the loudspeakers and avoid the risk of damage to equipment.

This equipment is double insulated and does not need a safety earth. It is important though that any equipment connected to it is earthed according to the manufacturers' instructions. This becomes more important as the number of units which are connected together increases.

Quad high fidelity equipment is designed to reproduce music at realistic levels, but there is a world of difference between the sound levels produced by a string quartet and a heavy metal group.

Please be aware that very high sound pressure levels can cause permanent damage to your hearing, and can also cause severe annoyance to neighbours.

INTRODUCTION

The Quad 707 is a high quality stereo power amplifier primarily intended for use in very high quality sound reproducing systems in the home and we hope that it will give you much pleasure. It will normally be used in conjunction with a Quad preamplifier though other preamplifiers can be used.

The Quad 77 series comprises a range of equipment which can be connected together using Quad's interlink system which we call QuadLink. The 77 series offers a two way infra red 77 System Console which provides you with a unique means of controlling and receiving information from your 77 series equipment. Some products of the 77 series also receive their power from the QuadLink bus. This power is provided by one of the special base units such as the 77 Integrated Amplifier, the 77 preamplifier or the 77 Audio Visual amplifier. You can also provide your Quad 77 series equipment with signals from your existing equipment though you will not be able to control their functions with Quad's 77 System Console.

You should read the following useful notes before you begin to install and use the equipment. The notes are directed towards the responsible adult who is responsible for the safe installation of the equipment. You should not allow minors to attempt electrical installation or to carry out changes.

The Quad 707 stereo power amplifier weighs approximately 12kg. It is built to be robust. Remember to check that any surface on which you place it is stable and is able to support this weight.

There are no user adjustable parts inside the equipment. You should refer any servicing to a qualified engineer or return the equipment to either the dealer or the Quad distributor.

Current Dumping

The 707 uses a current dumping output circuit, a Quad invention which eliminates many of the problems associated with transistor amplifiers and is covered by patents in several countries. In a current dumping amplifier there is in effect both a low power very high quality amplifier and a high power heavy duty amplifier. The low power amplifier controls the loudspeakers at all times calling on the high power amplifier to provide most of the muscle. The low power amplifier is so arranged - it carries an error signal - that provided the larger power transistors (the current dumpers) get within the target area of the required output current it will fill in the remainder accurately and completely. The reproduced quality is **solely** dependent on the small amplifier which because of its low power can be made very good indeed.

Problems of crossover distortion, quiescent current adjustment, thermal tracking and transistor matching all disappear. There are no internal adjustments or alignments and the choice of power transistor types is less restrictive.

The performance of the Quad 707 amplifier is as accurate as it is possible to achieve by careful design, selection of components and rigorous test procedures.

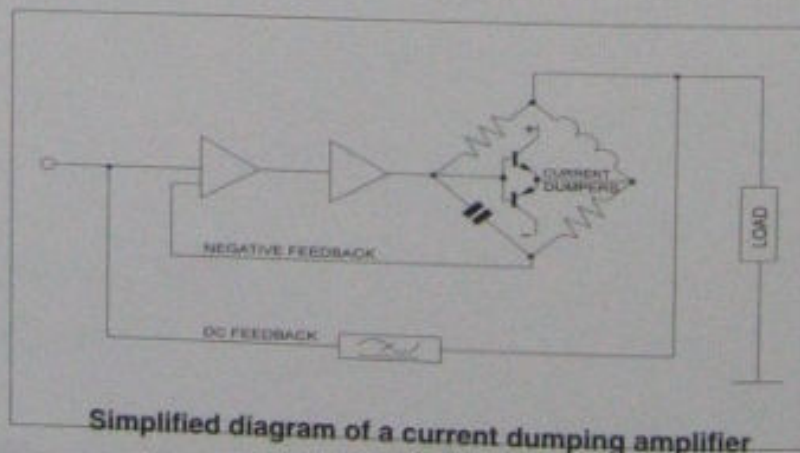

Simplified diagram of a current dumping amplifier

PACKING LIST AND UNPACKING THE EQUIPMENT

The packaging contains the following items:

The 707 power amplifier model 7777
The accessory pack containing:

one 1000mm long IEC plug and socket cable, QU2005A
one 1000mm long 77AMPBUS connector and cable, Q37404A
two Neutrik connectors, PPNL4FC

one user manual
one user registration card
one set of packing materials comprising:

one set of expanded polystyrene end cheeks
one cardboard carton
one polythene protective bag

You should retain the packing materials for future use or you may return them to your dealer. If you decide not to keep the packing, please dispose of it sensibly. The paper and plastics components are recoverable and should be taken to an appropriate recovery service.

You should consult the dealer from whom you purchased the equipment if any of these items are not present.

You should retain the user manual and the information concerning the date and place of purchase of this equipment for future reference.

GUARANTEE AND PRODUCT REGISTRATION

Your Quad 77 equipment is guaranteed against any defect in material and workmanship for a period of two years from the date of purchase. Within this period Quad will undertake replacement of defective parts free of charge provided that the failure was not caused by misuse, accident or negligence.

Your statutory rights within the territory in which you purchased the equipment are not affected by this guarantee.

A guarantee card is not provided because your guarantee begins on the day you purchased the equipment. Please fill in the product registration card and return if you would like to receive information on new Quad products.

Quad does carry out a regular review of its products and reserves the right to adjust the specifications and performance from time to time.

SERVICE ARRANGEMENTS

If your Quad equipment requires servicing you should return it to the supplier, the distributor for the country in which it was purchased or to Quad Electroacoustics Ltd. You should use the original packing. You should enclose a brief note with your name and address and the reason for returning the equipment.

Quad offers a same day service from Monday to Friday except for UK public holidays. Please telephone the number provided on your product registration card in order to make an appointment.

ACCESSORIES SUPPLIED

We have provided this equipment with a simple selection of accessories which will allow this equipment to work with other equipment such as your cassette tape recorder, video player or other HiFi equipment. The following is a selection of accessories which are available:

accessory description	quad part number
IEC mains cable 2m long fitted with UK plug	QUKES2B
IEC mains cable 2m long fitted with European plug	QE2P2S2
QuadLink bus cable 160mm	Q37414A
QuadLink bus cable 1m	Q37404A
Double ended phono cable 500mm	QP2P2SA
Double ended phono cable 1m	QP2P21A
Double ended phono cable 2m	QP2P22A
Quad loudspeaker cable 2.5 sqmm flat form, beige	QLSCF2S
Quad loudspeaker cable 4 sqmm round form, beige	QLSCR4S
Quad loudspeaker cable 4 sqmm round form, blue	QLSCR4B
Quad loudspeaker cable 4 sqmm round form, purple	QLSCR4P

Note that we can not supply loudspeaker cables terminated with 4mm plugs nor the 4mm plugs themselves.

INSTALLATION

The Quad 707 amplifier has no controls other than an on/off switch (which is normally left on) and may be mounted out of sight in a cabinet or other convenient location.

If used close to a record deck or other equipment susceptible to hum it may be necessary to increase the spacing between them.

To keep the bus connections simple place the 707 stereo power amplifier below the 77 preamplifier. Power amplifiers can be placed along side or out of sight using a long 77AMPBUS cable.

The amplifier will run warm, the actual temperature depending on the power output. A resettable current trip will automatically switch the amplifier off under gross overload or short circuit output etc. The fins of the heatsink should be kept clear of obstruction to allow adequate ventilation in normal use.

See **Amplifier Protection** - page 13.

Checking the AC Power Supply

The 707 amplifier is supplied in four versions suitable for connection to either 230V, 120V, 110V and 100V AC power supplies. Before connecting the amplifier to the AC supply check that you have the correct version - the operating voltage is clearly marked on the back. No damage will be caused if the amplifier is connected to a lower voltage than marked but the maximum output power will be lower than specified.

The Quad 707 can be converted from 240V to 120V and from 220V to 110V or vice versa by changing two soldered wire links on the power supply board, as well as replacing the current trip and the mains power input fuse. The rating label should also be changed.

Before connecting to the AC power supply check that the voltage range marked on the back corresponds with that of the supply.

Within the EC the nominal mains voltage which is provided to homes is 230Vac.

You should check with the dealer if you intend to use the equipment in regions which use different values of mains voltage. The dealer will be able to determine if a simple wiring change or a replacement transformer is needed.

If you are in any doubt what the correct operational voltage is you should ask a qualified electrician before applying power to the equipment. The Quad 707 power amplifier will work correctly within the tolerances of this voltage.

The mains supply fuse of the Quad 707 power amplifier is accessible on the rear panel when the IEC mains plug has been removed. In the rare event that it has broken you should first check for any obvious cause before replacing the fuse with one of the correct rating and type. The correct fuse values are:

Country or region	nominal mains voltage	fuse rating
Europe including UK	230Vac	T6.3AL slow blow 5x20mm
Japan	100Vac	T10AL slow blow 5x20mm
Korea, for example	220Vac	T6.3AL slow blow 5x20mm
USA, for example	115Vac	T10AL slow blow 5x20mm

You should switch off the equipment and remove the connection to the mains power outlet before changing the fuse.

Connecting to the AC Power Supply

The 707 amplifier is supplied with a 1m long AC supply lead fitted with standard 2-pin Euro connectors for connection between the amplifier **AC power in** and the **AC power out** socket fitted on the back of current Quad equipment. For connection to other equipment, or direct to the mains supply, your dealer can supply a longer lead to which a suitable plug should be fitted, as explained below:-

IMPORTANT - Fitting a mains plug.

The wires in the mains lead are coloured:

Brown = Live Blue = Neutral

The **Brown** wire must be connected to the terminal marked **L** or coloured **Red**. The **Blue** wire must be connected to the terminal marked **N** or coloured **Black**.

Note

When a 13A plug is used this should be fitted with 13A fuse, or if another type of plug is used, by a 13A fuse either in the plug or adaptor, or at the distribution board. If in doubt consult a qualified electrician.

Connection to the Preamplifier

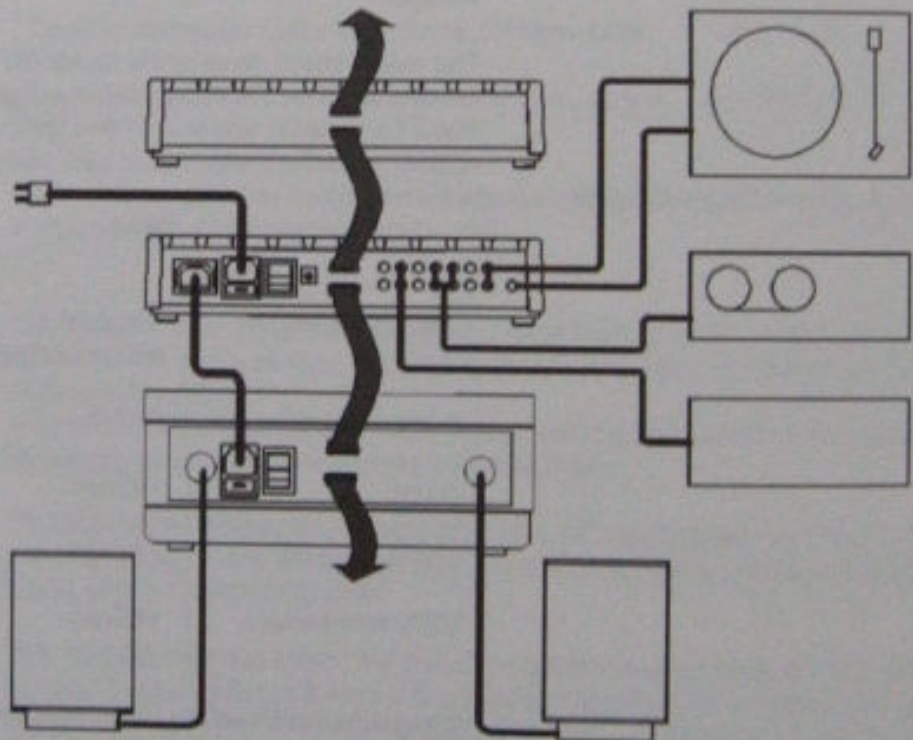

This diagram shows some Quad 77 system components in a typical arrangement.

FRONT VIEW

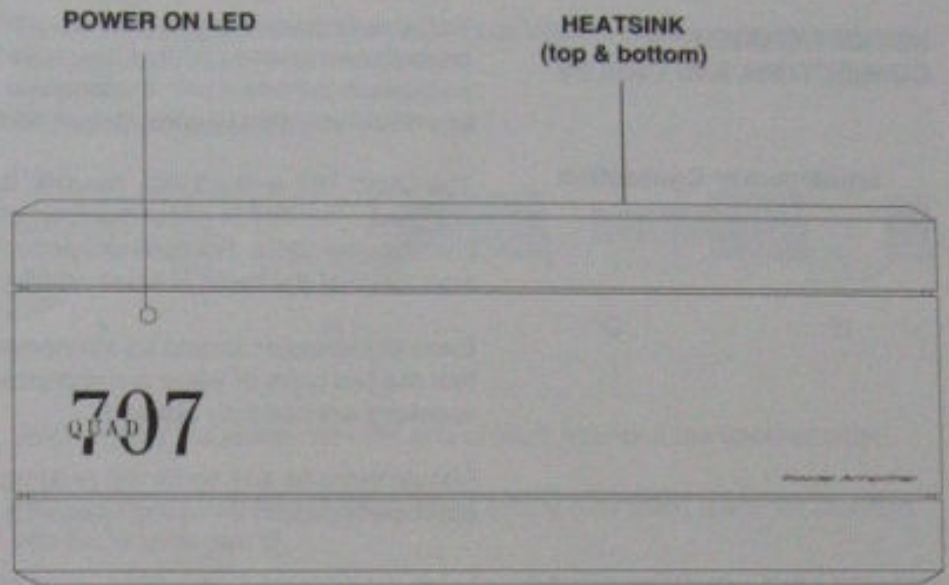

REAR VIEW

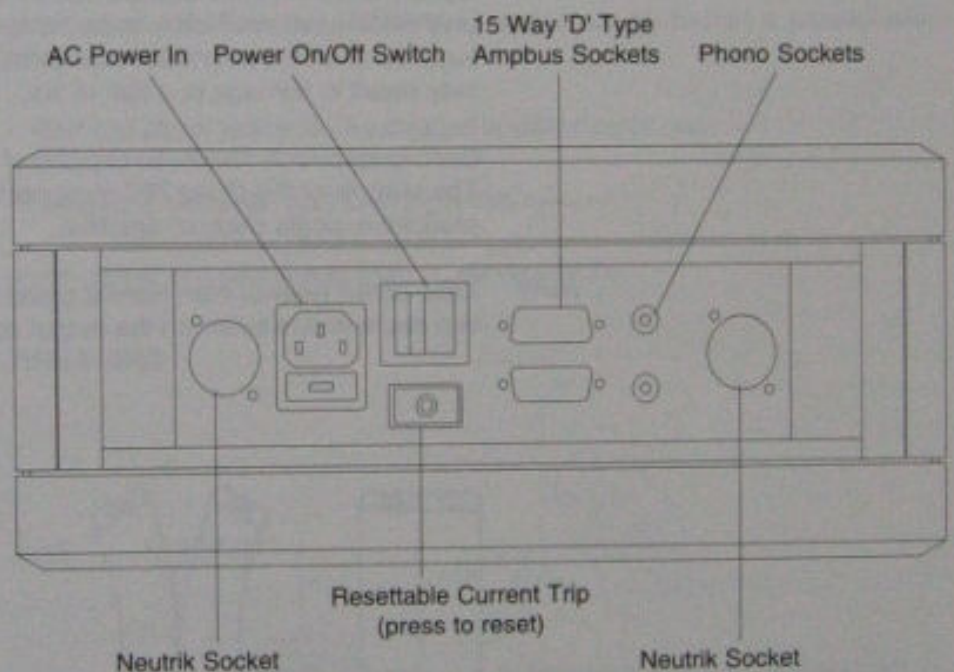

Connecting Sockets

- Phono Sockets:** Audio input connection from the audio output of your Quad control unit.
- Neutrik Sockets:** Audio output to the loudspeakers.
- AC Power In:** For the AC power supply input cable.
- Ampbus Sockets:** Sockets for feeding and receiving information via the Quadlink.

USE OF CORRECT CONNECTORS AND CABLES

You should ensure that any cables which are used with Quad equipment are properly terminated and that the cable is appropriate to the task. This is particularly important with loudspeaker cables and connections. If you are in any doubt you should consult your dealer.

Loudspeaker Connection

The Quad 707 is fitted with **Neutrik Speakon Connectors**. Two plugs are supplied. The 707 is unconditionally stable and can be used with any type of loudspeaker cable. For optimum performance it is necessary to ensure that the resistance of the cable is small relative to the loudspeaker impedance.

Each loudspeaker should be connected to the appropriate output sockets so that the two pairs of wires are connected in the same way, to ensure that the speakers are correctly phased.

Should there be any doubt the phasing can be checked experimentally. See **Loudspeaker Phasing** - page 13.

CONNECTING LOUDSPEAKERS

Loudspeaker cables should be carefully prepared. The Quad 77 series amplifiers may not be used with 4mm or similar styled connectors. The following sketches show how to prepare a loudspeaker cable for use with Quad power amplifiers and loudspeakers. We have used illustrations of Quad's round and flat loudspeaker cables as examples. Be careful to cut only the insulation which is to be removed. Make sure that you collect together all of the strands of wire as stray wires may cause shorting which may result in damage or a risk of fire.

Each loudspeaker should be capable of handling the full output of the amplifier. The outputs of the Quad 707 must not be connected in parallel or in series to produce a single channel amplifier.

Note Take care if heavier than normal grade loudspeaker cables are used as these can place undue strain on the output sockets.

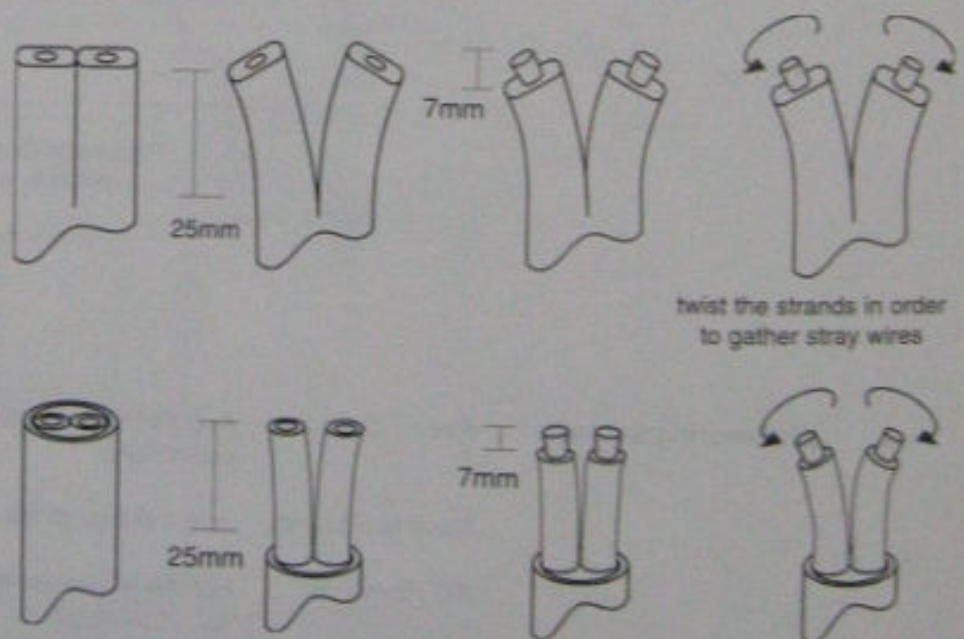

Neutrik Speaker Plug Assembly

The Neutrik plug comes in four main parts which when lined up properly slot into grooves through one another.

The parts are as follows:

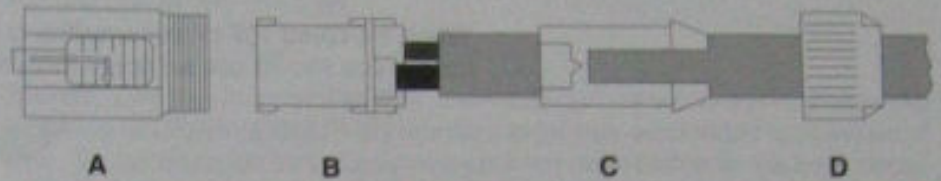

Strip 7mm of insulation from the end of each strand of the speaker cable.

Prepare bare wires by pushing copper tubing over them ready for insertion into sockets on part **B**.

Take speaker cable and thread part **D** on first and then part **C**.

Take part **B** and connect the red wire* to the socket marked +1 and secure with Allen key. Take the black wire* and connect to the socket marked -1 and secure with Allen key. Sockets +2 and -2 are connected in parallel with sockets +1 and -1.

* Red and Black refers to Quad round speaker cable only.

Take part **A** and push part **B** straight through.

Push part **C** into part **A** and then screw on part **D**.

Neutrik Plug Connection

ENGAGING

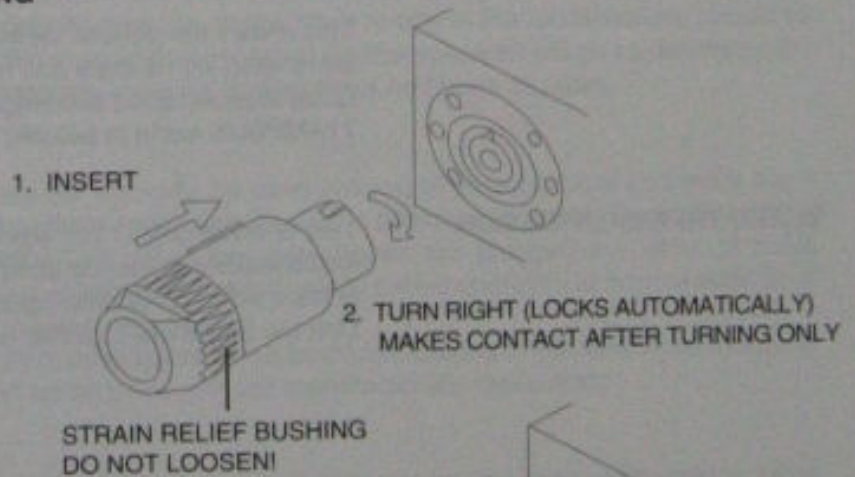

WITHDRAWAL

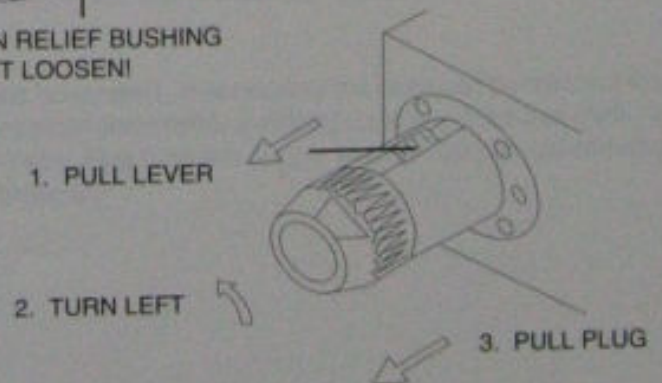

SIGNAL CONNECTION

When the Quad 707 power amplifier is used as part of a 77 system, you should use the 77AMPBUS lead supplied to connect to the output of the 77 preamplifier or 77 AV processor. Signal on the 77AMPBUS is in differential mode, which has performance advantages over unbalanced signal.

When the Quad 707 power amplifier is used with equipment other than 77 series, you should use an appropriate lead to connect to the phono input.

QUADLINK CABLE

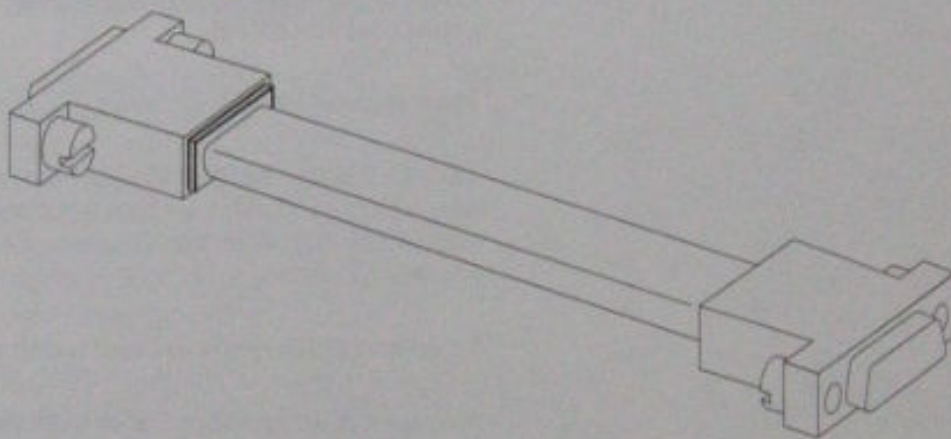

This shows the general view of a QUADLINK cable. The ends are terminated with a male and female form of the D type 15 way connector. Quad manufactures two lengths of this cable, 160mm and 1m. The 77AMPBUS cable is actually electrically and physically identical.

BI AND TRI-AMPLIFICATION

Two or three QUAD 707 stereo amplifiers can be used to bi or tri amplify loudspeakers or can be used in combination with a 77 stereo amplifier which is fitted with appropriate input connectors as an easy performance upgrade. Link the amplifiers together using QUAD 77AMPBUS connecting cable.

SWITCHING ON AND OFF

Switching On - Press the **on/off switch**. This has a rocker action, press the bottom to switch the amplifier on and the top to switch it off. Leave the amplifier switched on. In normal use it will be controlled via the **on/off switch** on the Quad control unit. The power on LED will glow **red** when the amplifier is in standby and **green** when on.

AMPLIFIER PROTECTION

The 707 amplifier is protected by a resettable current trip which interrupts the incoming AC Power supply if the amplifier is grossly overloaded for a period of time. To restore operation simply press the red reset button on the back panel. It is thus fully protected against gross overload, short-circuited output etc, but not necessarily against seriously inadequate ventilation.

LOUDSPEAKER PROTECTION

The loudspeaker manufacturer will usually state a maximum recommended amplifier power output, but as the maximum safe power for most loudspeakers is time and frequency dependent it is difficult to define it precisely for a musical signal. Some manufacturers will permit their loudspeakers to be used with amplifiers exceeding the quoted handling provided certain precautions are observed. This can sometimes be an advantage in enabling short duration peaks to be handled without overload. The advice of the loudspeaker manufacturer should always be obtained if in any doubt.

QUAD ELECTROSTATIC LOUDSPEAKERS

The 707 amplifier is fully compatible with the Quad ESL63 loudspeaker. It should not be used with the earlier model ESL which could be damaged by signal peaks unless a protection circuit is fitted inside each loudspeaker - please contact Quad Electroacoustics Ltd for details.

LOUDSPEAKER PHASING

If there is any doubt about the way the loudspeakers are connected their phasing can easily be checked by playing a mono source when the sound should appear to emanate from a point midway between the two loudspeakers. If this is indefinite then the connections to one of the loudspeakers should be reversed. When correctly connected the loudspeakers will give a definite centre sound source with more full bodied tenor and bass registers.

HEADPHONES

Headphones will normally be used instead of loudspeakers and there are a number of suitable switch units available designed to enable the loudspeakers to be switched off when the headphones are plugged in. Most of these incorporate a simple attenuator circuit to permit operation at normal settings of the control unit volume control.

Electrostatic or other types of headphones requiring a high level input should be operated in accordance with the manufacturer's instructions.

MAINTENANCE

No routine maintenance is required. If necessary the case can be cleaned with a soft brush or, for more stubborn marks, a slightly moistened lint-free cloth. In this case remove the mains plug from the supply socket. Do not use cleaning agents, solvents or abrasives.

SPECIFICATION

(Measurements made with 230V supply, one channel driven and apply to either channel.)

Power output:	120W into 8 Ω (see graph), 14A peak. 220W into 4 Ω (see graph), 14A peak.
Distortion (Dtot):	<0.01% at 20 Hz any level up to 120W. <0.01% at 1 kHz any level up to 120W. <0.03% at 20 kHz any level up to 120W. (Continuous sine wave into 8 Ω resistive load)
Output, internal impedance and DC offset:	1.5 μ H in series with 0.05 Ω . DC offset typically 7 mV.
Frequency response:	-0.25 dB at 20 Hz and 20 kHz, ref 1 kHz. -1.0 dB at 13 Hz and 40 kHz, ref 1 kHz.
Power response:	-0.25 dB at 20 Hz and 20 kHz, ref 1 kHz.
Input sensitivity:	775 mV for 140W into 8 Ω .
Input Impedance:	20 k Ω .
Input overload:	Instantaneous recovery up to +15 dB overload.
Crosstalk:	-80 dB at 1 kHz. -65 dB at 10 kHz. (input loaded by 1 k Ω)
Hum and noise:	Unweighted -105dB ref 140W (15.7 kHz measurement bandwidth).
Stability:	Unconditionally stable with any load and input.
Mains voltage:	240V-120V, 220V-110V, and 100V AC. See rating details on back of unit (Requires changing two links on power board, or changing mains transformer, plus current trip and F1 AC power fuse).
Power consumption:	35-750W depending on output power level.
Protection; Fuse (F1):	AC power. 6.3A anti-surge for 220V - 240V. 10A anti-surge for 100V - 110V - 120V.
Fuse (F2):	HT rail. 6.3A anti-surge, one per channel.
Current trip:	Resettable, 2A for 220 - 240V. 4A for 100V - 110V - 120V.
Dimensions:	Width 321 mm; height 140 mm; depth 238 mm (plus connectors) approx.
Weight:	12 kg approx.

*The right is reserved to alter performance and specification as required.
This equipment complies with the radio interference requirements as laid
down in EEC (European Economic Community) regulations.*

Power Output Graph

